

QUAD DIFFERENTIAL LINE DRIVER IC WITH OPEN-COLLECTOR OUTPUTS AND ENABLE FUNCTION

ET7273B

FEATURES

- Supply Voltage Range 3.5V to 30V
- Operation to 800KHz
- CMOS and TTL Compatible Inputs
- Outputs RS-422A Compatible
- High Impedance Buffered Inputs with Hysteresis
- **NPN Open-Collector outputs**
- 80mA peak SINK current
- Outputs Protected by Thermal Shut-Down

APPLICATIONS

- Optical Encoders
- Industrial Controls

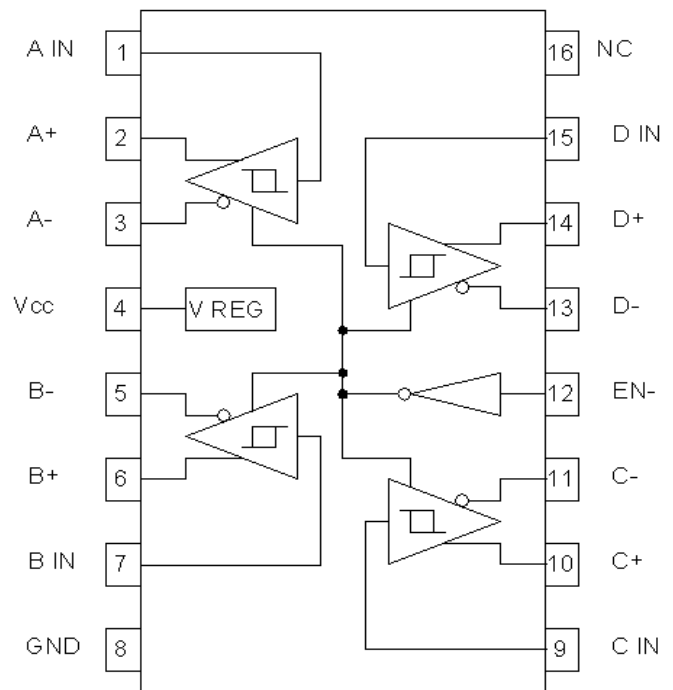

DESCRIPTION

These line drivers are similar in function to the ET7272, only in an open-collector format. The V_{CC} pin powers the internal logic only. Output voltage is dependent on the customer supplied voltage, up to a maximum of 30V. There is essentially no difference in output swing or performance with $V_{CC(Logic)}$ values from 3.5V-30V. Internal clamp diodes allow trouble-free operation when driving cable lengths exceeding 100 meters. The outputs are protected by initiating shutdown when junction temperatures exceed safe limits. This feature assures highly reliable operation in harsh environments. Heat sinking is aided by having pin 8 directly connected to the ASIC substrate inside the package.

ABSOLUTE MAXIMUM RATINGS

Parameter	Symbol	Min.	Max.	Units	Ref.
Operating Temperature Range	T_A	-55	115	°C	Note 1
Supply Voltage Range	V_{CC}	3.5	30	V	

ETIC RESERVES THE RIGHT TO MAKE CHANGES AT ANY TIME TO IMPROVE THE DESIGN AND TO SUPPLY THE BEST PRODUCT.

ELECTRICAL CHARACTERISTICS

Unless otherwise specified, $T_A = 25^\circ\text{C}$ and $EN- < 0.8\text{V}$.

Parameters	Symbol	Min.	Typ.	Max.	Units	Test Conditions
Overtemp Operate Point (junction)	T_{JOP}		172		$^\circ\text{C}$	Note 1
Overtemp Release Point (junction)	T_{JRP}		136		$^\circ\text{C}$	Note 1
Vcc Voltage Range	Vcc	3.5	5	30	V	
Supply Current Vcc1	Icc1		11.9	16.0	mA	
Supply Current Vcc2	Icc2		2.5	3.4	mA	Vcc = 5V, EN- >2V
Supply Current Vcc3	Icc3		12.1	18.5	mA	Vcc = 30V
Supply Current Vcc4	Icc4		2.6	3.5	mA	Vcc = 30V, EN- > 2V
Enable Input Threshold	V_{THE}	0.8	1.5	2	V	
Enable Low Level Input Current	I_{ILE}	-10	0	10	μA	$V_{IN} = 0\text{V}$, Vcc = 5V
Enable High Level Input Current	I_{IHE}	-	108	150	μA	$V_{IN} = 5\text{V}$, Vcc = 5V
High Impedance Output Leakage	I_{OZ}	-4.0	0.0	4.0	μA	Vcc = 5V, EN- > 2V, Output at 15V
Input Positive-Going Threshold	V_{T+}	1.05	1.25	1.45	V	
Input Negative-Going Threshold	V_{T-}	0.75	0.95	1.15	V	
Input Hysteresis	V_H	-	0.3	-	V	
Low Level Input Current	I_{IL}		-0.1	-4.0	μA	$V_{IN} = 0\text{V}$, Vcc = 5V
High Level Input Current	I_{IH}		0	4.0	μA	$V_{IN} = 5\text{V}$, Vcc = 5V
Low Level Output1	V_{OL1}		375	500	mV	$I_{OL} = 20\text{mA}$, Vcc = 5V, $V_{OC} = 30\text{V}$
Low Level Output2	V_{OL2}		370	500	mV	$I_{OL} = 20\text{mA}$, Vcc = 30V, $V_{OC} = 30\text{V}$
High Level Output Current1	I_{OH1}	-	0	10	μA	Vcc = 5V, $V_{OC} = 30\text{V}$
High Level Output Current2	I_{OH2}	-	0	10	μA	Vcc = 30V, $V_{OC} = 30\text{V}$

ETIC RESERVES THE RIGHT TO MAKE CHANGES AT ANY TIME TO IMPROVE THE DESIGN AND TO SUPPLY THE BEST PRODUCT.

East Texas Integrated Circuits USA • 1221 W. Campbell Road Suite 115 • Richardson, Texas 75080 • Tel (972) 234-5656 • Fax (972) 234-5657
 Visit our website at www.easttexasic.com, or send us email at sales@easttexasic.com.

AC SWITCHING CHARACTERISTICS

Load is 470 ohms and 1000pF, output to its compliment, and 470 ohms each output to V_{oc} .

Parameters	Symbol	Min.	Typ.	Max.	Units	Test Conditions
Propagation delay, rising input 50% point to zero crossing of differential outputs	T_{PLH}	-	232	325	ns	
Propagation delay, falling input 50% point to zero crossing of differential outputs	T_{PHL}	-	236	330	ns	
Output Rise Time	T_R	-	516	722	ns	
Output Fall Time	T_F	-	516	722	ns	

NOTES:

1. This is not a test parameter, but for information only.
2. Unused inputs should be connected to ground.
3. Do not leave pin 12 open. In applications which do not use the enable function, this pin should be tied to ground.



PACKAGE

Chip Only
16 Lead SOIC

SUFFIX

-C
-SOP

ETIC RESERVES THE RIGHT TO MAKE CHANGES AT ANY TIME TO IMPROVE THE DESIGN AND TO SUPPLY THE BEST PRODUCT.

East Texas Integrated Circuits USA • 1221 W. Campbell Road Suite 115 • Richardson, Texas 75080 •
Visit our website at www.easttexasic.com, or send us email at sales@easttexasic.com.

PACKAGE

Chip Only
16 lead SOIC

SUFFIX

-C
-SOP