

INTERPOLATION DEVICE

(Interpolation factors of 1X or 10X)

ET2110

PRELIMINARY DATA

[Contact Sales](#)
[Visit web site](#)

FEATURES

- Interpolation factor pin selectable (1X/10X)
- Index gating pin selectable (90/180 electrical degrees of interpolated pulse)
- Leading edge of gated index pulse occurs at 270 electrical degrees of analog input cycle, regardless of interpolation factor selected
- Interfaces directly with ET2010 Analog Signal Processor and ET7272 Line Driver
- Handles Sine/Cosine inputs from DC to 125KHz
- Open-collector outputs with internal 4K-ohm pull-up resistors are TTL and CMOS compatible
- Sine/Cosine input voltage range 400mVpp to 4Vpp on 2.5VDC reference
- Outputs sink up to 4mA
- Single supply operation

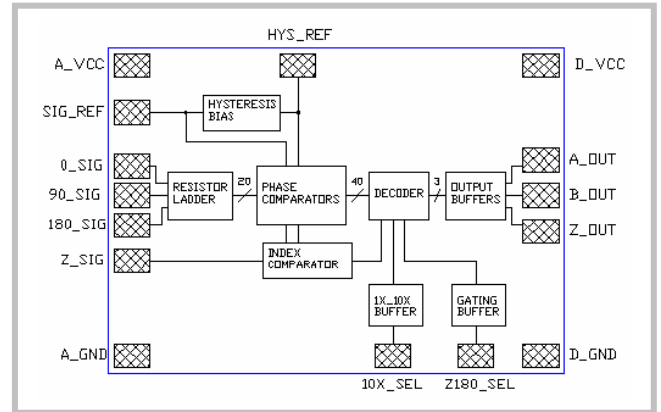

BLOCK DIAGRAM

This part is available in a 20 lead SSOP package, **lead-free & green**, or as die.

Package

Die
20 Lead SSOP

Suffix

-C
-SS

DESCRIPTION

This ET2110 is a monolithic bipolar integrated circuit designed to facilitate increased resolution in optical encoder applications by converting the incoming sine and cosine signals to an interpolated quadrature digital output at 1 or 10 times the input frequency. Please refer to the **Timing Diagram**. The device inputs receive photodiode signals which have been amplified and conditioned to optimize the interpolation function. This conditioning may be obtained from a companion device, the analog signal processor, ET2010. Following interpolation processing by the ET2110, the output signal can be fed into a line driver device, such as the ET7272, for driving extended loads. Please see the **Application Circuit**. **Device is pin for pin compatible with ET2015 and ET2024.**

In addition to processing the data channel information, the ET2110 provides a channel for the index signal which controls the gating of the index pulse relative to the 0° and 90° input waveforms. Index gating is provided to generate a pulse that commences at 270 electrical degrees of the analog input cycle. Width of the index pulse is either 90 or 180 electrical degrees of the interpolated pulse (pin selectable).

DESIGN SPECIFICATIONS

Parameter	Symbol	Min.	Max.	Units	Comments
Operating Temperature Range	T _A	-40	120	°C	
Storage Temperature Range	T _S	-55	150		
Supply Voltage Range	V _{CC}	4.5	5.5	V	
Quadrature Interpolation Factors		1X	10X	--	
Quadrature Error (1X mode)	E _{1X}	-22	22	ed	V _{IN} = 1.6Vpp
Quadrature Error (10X mode)	E _{10X}	-45	45	ed	V _{IN} = 1.6Vpp
Frequency Response at Digital Outputs	f _{CO}	1000	--	KHz	
Internal Pull-up Resistor	R _{INT}	3.0	5.0	KOhm	

ELECTRICAL CHARACTERISTICS

Unless otherwise specified, typical values given at V_{CC}=5V, T_A = 25°C, and V_{IN} = 1.6V_(P-P).

Parameters	Symbol	Min.	Typ.	Max.	Units	Test Conditions
Analog Supply Current	I _{CCA}	--	15.0	18.0	mA	V _{CC} = 5.5V
Digital Supply Current	I _{CCD}	--	6.0	8.0	mA	V _{CC} = 5.5V
Hysteresis REF Voltage	V _{REF}	2.48	2.53	2.58	V	
SIG_REF Input Current @ 2.5V	I _{SIG_REF}	--	-5	-50	uA	
Z_SIG Input Current	I _{Z SIG}	--	<1	10	μA	V _{IN} = 0V, V _Z = 5.5V
0_SIG, 90_SIG, and 180_SIG Input Current		-2	--	2	mA	
Low Level Output Voltage	V _{OL}	--	270	325	mV	With R _{EXT} = 3.3K
High Level Output Voltage	V _{OH}	5.0	5.1	--	V	V _{CC} = 5.5V, I _{OH} = -100uA

Pin Descriptions

Pin #	Pin Name	Description/Use
2	HYSTERESIS_REFERENCE	Intended to be left open.
3	ANALOG_VCC	Voltage supply for analog portion of circuit. Bypass to A_GND.
5	ANALOG_GND	Return for analog supply voltage.
6	SIGNAL_REFERENCE	An input and the DC offset level of the sine wave inputs. Bypass to A_GND.
7,8,9	0_SIG, 90_SIG, 180_SIG	Sine wave inputs. When 0_SIG leads 90_SIG, then A leads B at the quadrature outputs. Amplitude should be about 1.6Vpp.
10	Z_SIG	High impedance input with comparator threshold at 2.5V.
11	Z180_SEL	High impedance input to select width of the index pulse. When >2.5V, Z_OUT= 180/X electrical degrees, gated on B_LOW. When <2.5V, Z_OUT= 90/X electrical degrees, gated on (A_LOW AND B_LOW).
12	10X_SEL	High impedance input to select interpolation factor. When >2.5V, the factor is 10X and when <2.5V the factor is 1X.
13	D_GND	Return for the digital supply voltage.
14,16,18	B_OUT, Z_OUT, A_OUT	NPN open collector with internal 4K pull-up resistor.
20	D_VCC	Voltage supply for the digital portion of circuit. Bypass to D_GND.
15,17,19	n/c	While there is no internal connection, these pins should be tied to D_GND on the PCB to shield against output-output crosstalk.

Application

Please refer also to the block diagram. The sine and cosine inputs (0_SIG, 90_SIG, 180_SIG) should be in the range of 400mVpp to 4Vpp, with a DC offset of 2.5V. Care must be taken to limit the noise on the analog inputs to avoid spurious signals at the outputs. The hysteresis of the phase comparators is 20mV, and while a large input signal may seem advantageous, it is so only as long as the noise is well below the 20mV level. Therefore, from a practical standpoint, the input levels are often limited to the 1.5Vpp range. The ET2110 accepts the DC offset of the analog signals as an input at the SIG_REF pin. The outputs are NPN collectors with 4K pull-ups. For high-frequency applications, output rise time can be reduced by addition of external pull-up resistors as low as 1.5K, as long as the 4mA limit on external loading is not exceeded. For applications that use photodiode sensing, ETIC offers the ET2010 Analog Signal Processor for generating sine/cosine signals compatible with the ET2110. Please refer to the Application Circuit, which handles inputs from photodiode sensors and processes them through to line driver outputs.

Application Circuit

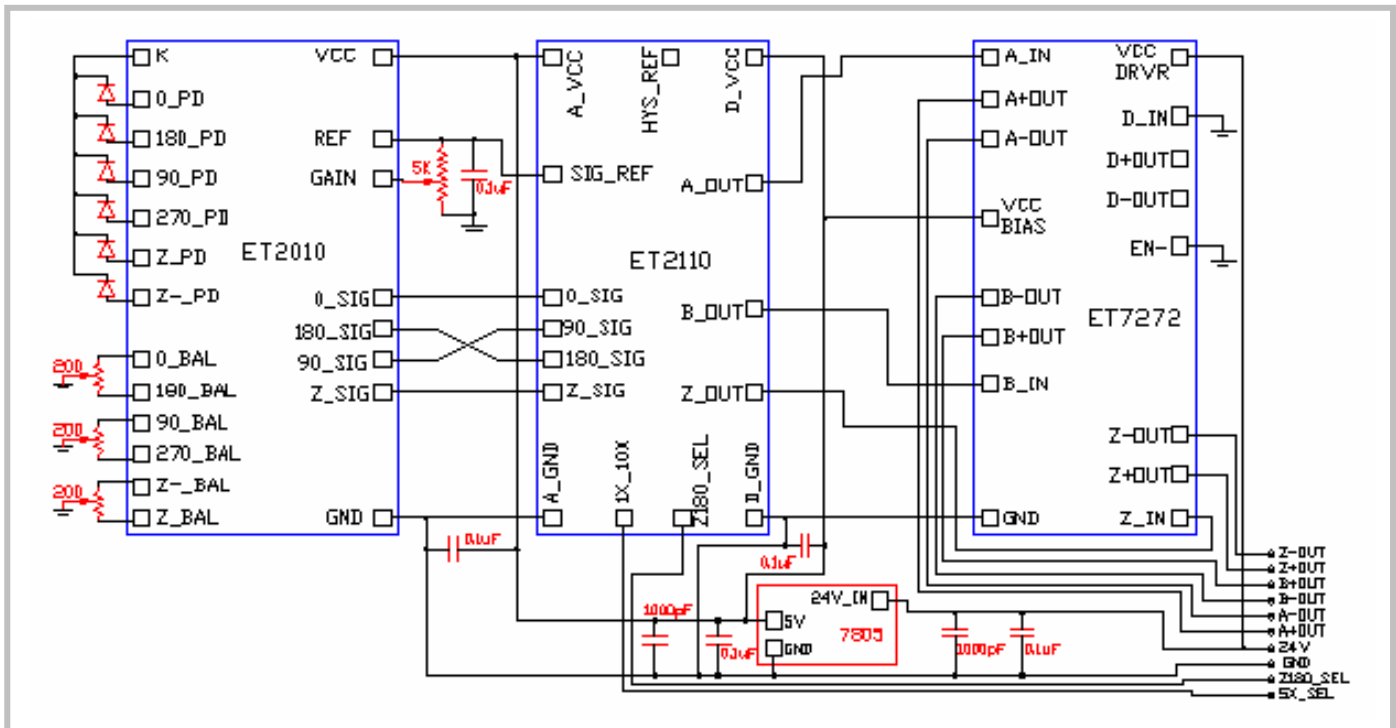

Disk Optimization

The placement of the index feature on the encoder disk can be optimized, depending on the variety of interpolation factors and index widths that will be used with a given disk. The basic placement for the index pulse would be centered on 0°, and with a width of one cycle (360° electrical). At this point, the 0°_SIG (Sine) is at its positive zero crossing, and the 90°_SIG (Cosine) is at its negative peak. This gives the best manufacturing tolerance for the Z180 pulse in 1X mode, which is the worst case. With this placement, the gated Z pulses from the 2110 will be as shown below in the Timing Diagram. If a disk is to be used in 10X interpolation mode, and with both Z90 and Z180 index gating modes, then the index feature should be centered at 279 degrees of the analog input cycle. If the application is designed uniquely for 10X interpolation in the Z90 mode, the index feature on the disk should be centered at 274.5 degrees. Optimization of the disk in this manner affords a wider margin for misalignment, and can therefore enhance the ease of assembly in volume production.

Timing Diagram

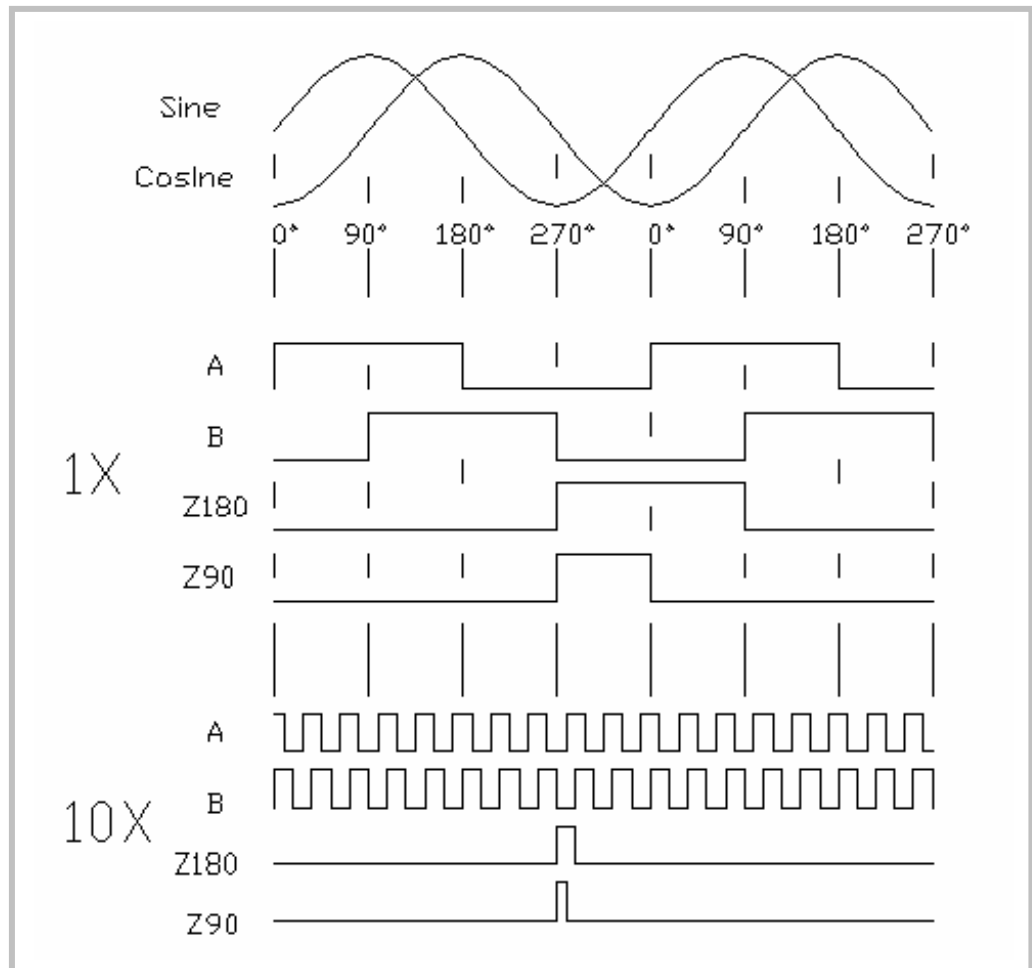

ET2110 -SS

Package Drawing for 20L SSOP

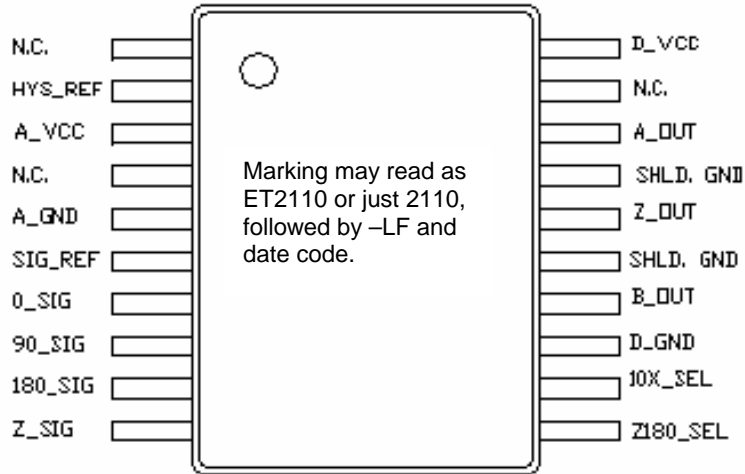

ET2110 - C

Size = .134" x .149" (3404μ x 3785μ)
 Thickness = .011"-.013" (279μ-330μ)
 Pad coordinates are in microns.

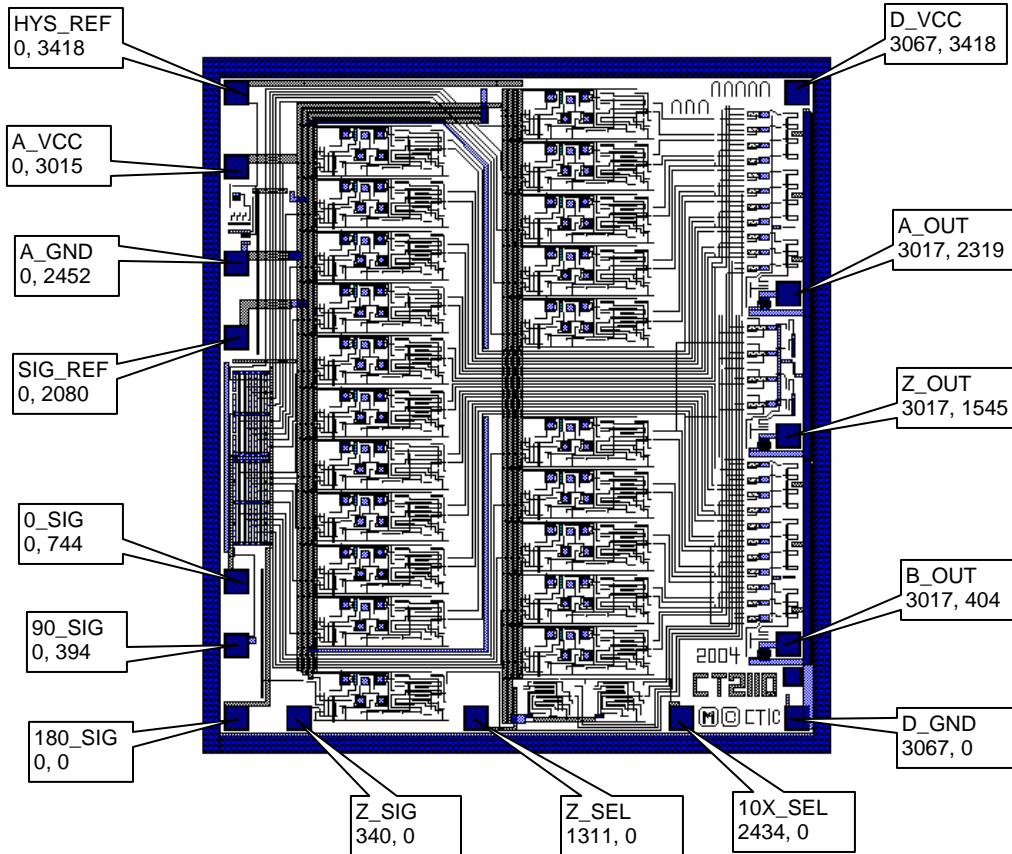

Preliminary Data – Subject to Change